

# Plate Heat Exchangers for General Refinery Services

## Part 2—Brazed Aluminum Plate-fin Heat Exchangers

ANSI/API STANDARD 662  
FIRST EDITION, FEBRUARY 2006

REAFFIRMED, FEBRUARY 2011

**ISO 15547-2:2005 (Identical), Petroleum, petrochemical and natural gas industries—Plate-type heat exchangers—Part 2: Brazed aluminum plate-fin heat exchangers**



AMERICAN PETROLEUM INSTITUTE



## Special Notes

API publications necessarily address problems of a general nature. With respect to particular circumstances, local, state, and federal laws and regulations should be reviewed.

Neither API nor any of API's employees, subcontractors, consultants, committees, or other assignees make any warranty or representation, either express or implied, with respect to the accuracy, completeness, or usefulness of the information contained herein, or assume any liability or responsibility for any use, or the results of such use, of any information or process disclosed in this publication. Neither API nor any of API's employees, subcontractors, consultants, or other assignees represent that use of this publication would not infringe upon privately owned rights.

API publications may be used by anyone desiring to do so. Every effort has been made by the Institute to assure the accuracy and reliability of the data contained in them; however, the Institute makes no representation, warranty, or guarantee in connection with this publication and hereby expressly disclaims any liability or responsibility for loss or damage resulting from its use or for the violation of any authorities having jurisdiction with which this publication may conflict.

API publications are published to facilitate the broad availability of proven, sound engineering and operating practices. These publications are not intended to obviate the need for applying sound engineering judgment regarding when and where these publications should be utilized. The formulation and publication of API publications is not intended in any way to inhibit anyone from using any other practices.

Any manufacturer marking equipment or materials in conformance with the marking requirements of an API standard is solely responsible for complying with all the applicable requirements of that standard. API does not represent, warrant, or guarantee that such products do in fact conform to the applicable API standard.

These materials are subject to the copyright claims of ISO, ANSI and API. All rights reserved. No part of this work may be reproduced, stored in a retrieval system, or transmitted by any means, electronic, mechanical, photocopying, recording, or otherwise, without prior written permission from the publisher.

Contact the Publisher, API Publishing Services, 1220 L Street, N.W.,  
Washington, D.C. 20005.

*Copyright © 2006 American Petroleum Institute*

## API Foreword

Nothing contained in any API publication is to be construed as granting any right, by implication or otherwise, for the manufacture, sale, or use of any method, apparatus, or product covered by letters patent. Neither should anything contained in the publication be construed as insuring anyone against liability for infringement of letters patent.

This document was produced under API standardization procedures that ensure appropriate notification and participation in the developmental process and is designated as an API standard. Questions concerning the interpretation of the content of this publication or comments and questions concerning the procedures under which this publication was developed should be directed in writing to the Director of Standards, American Petroleum Institute, 1220 L Street, N.W., Washington, D.C. 20005. Requests for permission to reproduce or translate all or any part of the material published herein should also be addressed to the director.

Generally, API standards are reviewed and revised, reaffirmed, or withdrawn at least every five years. A one-time extension of up to two years may be added to this review cycle. Status of the publication can be ascertained from the API Standards Department, telephone (202) 682-8000. A catalog of API publications and materials is published annually and updated quarterly by API, 1220 L Street, N.W., Washington, D.C. 20005.

Suggested revisions are invited and should be submitted to the Standards and Publications Department, API, 1220 L Street, NW, Washington, DC 20005, [standards@api.org](mailto:standards@api.org).

# Contents

	Page
<b>API Foreword</b> .....	<b>ii</b>
<b>Foreword</b> .....	<b>iv</b>
<b>Introduction</b> .....	<b>v</b>
<b>1 Scope</b> .....	<b>1</b>
<b>2 Terms and definitions</b> .....	<b>1</b>
<b>3 General</b> .....	<b>3</b>
<b>4 Proposal information required</b> .....	<b>3</b>
<b>5 Drawings and other data requirements</b> .....	<b>4</b>
<b>6 Design</b> .....	<b>5</b>
<b>7 Materials</b> .....	<b>7</b>
<b>8 Fabrication</b> .....	<b>8</b>
<b>9 Inspection and testing</b> .....	<b>12</b>
<b>10 Preparation for shipment</b> .....	<b>14</b>
<b>Annex A (informative) Recommended practice</b> .....	<b>15</b>
<b>Annex B (informative) Plate-fin heat exchanger checklist</b> .....	<b>18</b>
<b>Annex C (informative) Plate-fin heat exchanger data sheets</b> .....	<b>19</b>
<b>Bibliography</b> .....	<b>26</b>

## Foreword

ISO (the International Organization for Standardization) is a worldwide federation of national standards bodies (ISO member bodies). The work of preparing International Standards is normally carried out through ISO technical committees. Each member body interested in a subject for which a technical committee has been established has the right to be represented on that committee. International organizations, governmental and non-governmental, in liaison with ISO, also take part in the work. ISO collaborates closely with the International Electrotechnical Commission (IEC) on all matters of electrotechnical standardization.

International Standards are drafted in accordance with the rules given in the ISO/IEC Directives, Part 2.

The main task of technical committees is to prepare International Standards. Draft International Standards adopted by the technical committees are circulated to the member bodies for voting. Publication as an International Standard requires approval by at least 75 % of the member bodies casting a vote.

Attention is drawn to the possibility that some of the elements of this document may be the subject of patent rights. ISO shall not be held responsible for identifying any or all such patent rights.

ISO 15547-2 was prepared by Technical Committee ISO/TC 67, *Materials, equipment and offshore structures for petroleum, petrochemical and natural gas industries*, Subcommittee SC 6, *Processing equipment and systems*.

This first edition of ISO 15547-2, together with ISO 15547-1, cancels and replaces ISO 15547:2000, of which it constitutes a technical revision.

ISO 15547 consists of the following parts, under the general title *Petroleum, petrochemical and natural gas industries — Plate-type heat exchangers*:

- *Part 1: Plate-and-frame heat exchangers*
- *Part 2: Brazed aluminium plate-fin heat exchangers*

## Introduction

Some of the requirements within this part of ISO 15547 have been extracted from the standards of the brazed aluminium plate-fin heat exchanger manufacturers' association (ALPEMA).

Users of this part of ISO 15547 should be aware that further or differing requirements may be needed for individual applications. This part of ISO 15547 is not intended to inhibit a vendor from offering, or the purchaser from accepting, alternative equipment or engineering solutions for the individual application. This may be particularly applicable where there is an innovative or developing technology. Where an alternative is offered, the vendor should identify any variations from this part of ISO 15547 and provide details.

A recommended practice is included within this part of this International Standard (see Annex A).

This part of ISO 15547 requires the purchaser to specify certain details and features.

A bullet (●) at the beginning of a clause or subclause indicates a requirement for the purchaser to make a decision or provide information (for information, a checklist is provided in Annex B).

In this part of ISO 15547, where practical, US Customary units are included in parentheses for information.

# Petroleum, petrochemical and natural gas industries — Plate-type heat exchangers —

## Part 2: Brazen aluminium plate-fin heat exchangers

### 1 Scope

This part of ISO 15547 gives requirements and recommendations for the mechanical design, materials selection, fabrication, inspection, testing, and preparation for shipment of brazed aluminium plate-fin heat exchangers for use in petroleum, petrochemical and natural gas industries.

### 2 Terms and definitions

For the purposes of this document, the following terms and definitions apply.

#### 2.1

##### heat transfer area

sum of the primary and secondary heat transfer surface areas of all heat-transfer passages in contact with a stream

See Figure 1.

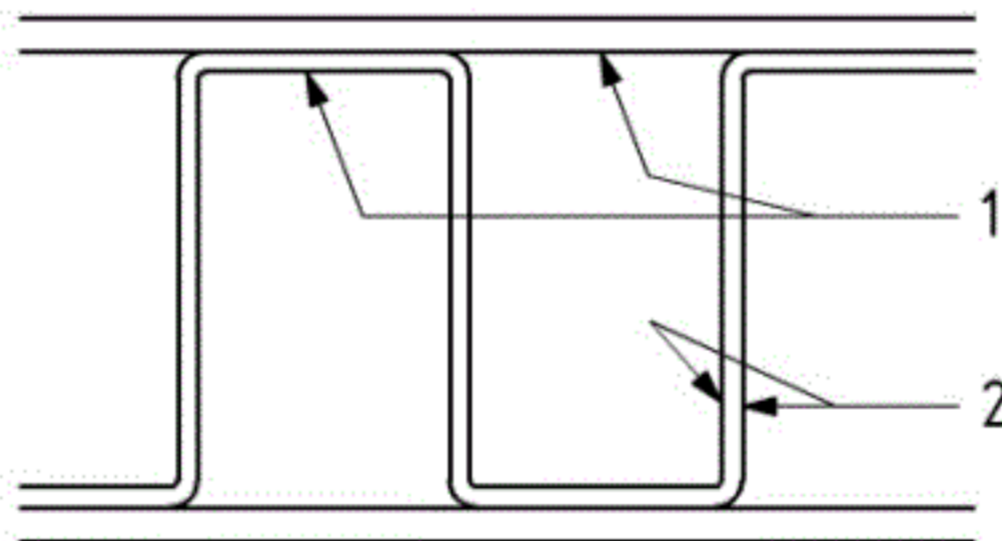

#### Key

- 1 primary heat transfer surface
- 2 secondary heat transfer surface

NOTE 1 The primary heat transfer surface within the plate-fin heat exchanger consists of the bare parting sheet and the fin base directly brazed to the parting sheet.

NOTE 2 The secondary heat transfer surface is provided by the fins. This area includes both sides of the fins where they are in contact with the fluid.

**Figure 1 — Cross-sectional view of fin and parting sheet — Heat transfer area**

**2.2**

**item number**

purchaser's identification number for a plate-fin heat exchanger

**2.3**

**minimum design metal temperature**

lowest metal temperature at which pressure-containing elements can be subjected to design pressure

EXAMPLE Ambient temperature, process fluid temperature.

**2.4**

**plate-fin heat exchanger**

heat exchanger consisting of a block (core) of alternating layers (passages) of corrugated fins

See Figure 2.

NOTE 1 The layers are separated from each other by parting sheets and sealed along the edges by means of side bars, and are provided with inlet and outlet ports for the streams. The block is bounded by cap sheets at the top and bottom.

NOTE 2 All the layers carrying the same stream are connected together by headers (inlet, outlet, intermediate) directly attached by welding onto the brazed core.

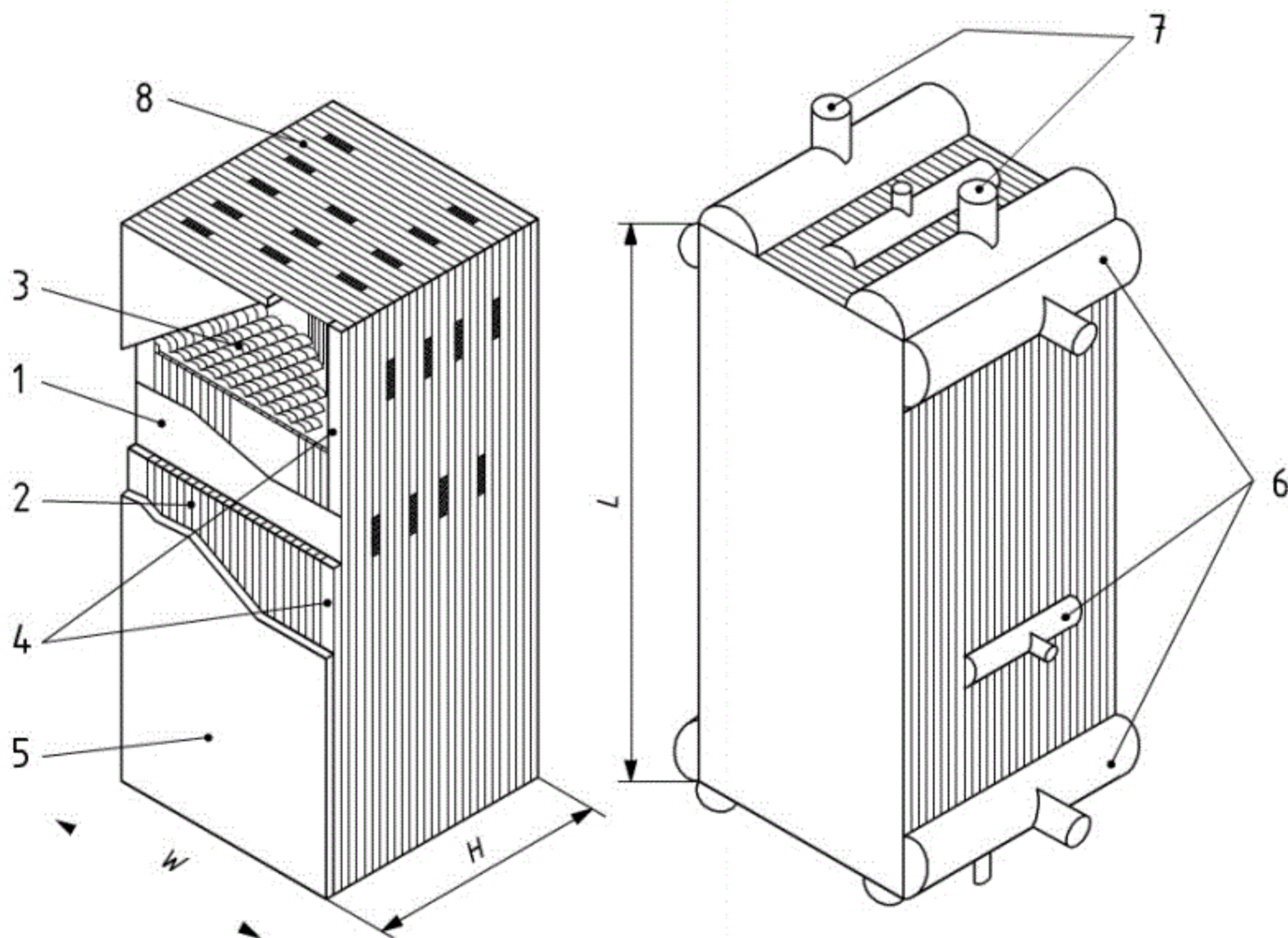

**Key**

- |            |                      |                |
|------------|----------------------|----------------|
| $H$ height | 1 parting sheet      | 5 cap sheet    |
| $L$ length | 2 heat transfer fins | 6 headers      |
| $W$ width  | 3 distributor fins   | 7 nozzles      |
|            | 4 side bars          | 8 block (core) |

**Figure 2 — Typical brazed aluminium plate-fin heat exchanger and components**



**2.5****pressure design code**

recognized pressure vessel standard specified or agreed by the purchaser

EXAMPLE ASME Section VIII, EN 13445.

**2.6****structural welding code**

recognized structural welding code specified or agreed by the purchaser

**3 General**

- **3.1** The pressure design code shall be specified or agreed by the purchaser. Pressure components shall comply with the pressure design code and the supplemental requirements in this part of ISO 15547.

The structural welding code shall be specified or agreed by the purchaser.

**3.2** Annex A provides some recommended practices for information.

- **3.3** The vendor shall comply with the applicable local regulations specified by the purchaser.
- **3.4** If specified by the purchaser, or if required by regulations, the vendor shall register each plate-fin heat exchanger.

**3.5** Further information on brazed aluminium plate-fin heat exchangers can be found in the ALPEMA standards <sup>1)</sup>.

**4 Proposal information required**

**4.1** The vendor shall provide a completed data sheet, including materials of construction. An example of a suitable format is given in Annex C.

**4.2** The vendor shall specify operating limitations, e.g. temperature limits.

**4.3** The vendor shall include a detailed description of any exception to the specified requirements.

**4.4** The first-time use of a plate-fin heat exchanger design, component or material by the vendor for the purchaser's intended service shall be clearly indicated by the vendor.

**4.5** The vendor shall provide recommended strainer requirements for each stream.

- **4.6** If a mercury-tolerant design is specified by the purchaser, the vendor shall provide details of special design, manufacturing techniques and operating procedures.

---

1) The standards of the Brazed Aluminium Plate-Fin Heat Exchanger Manufacturers' Association, 29 Cleveland, Abingdon, Oxon, OX14 2EQ, UK.

## 5 Drawings and other data requirements

### 5.1 Drawings

**5.1.1** The vendor shall furnish general arrangement drawings for each plate-fin heat exchanger for review. The drawings shall include the following information:

- a) service, item number, project name and location, vendor's shop order number and purchaser's order number;
- b) maximum allowable working pressure, design pressure including vacuum if applicable, test pressure, maximum design temperature, minimum design metal temperature and any restrictions regarding testing or operation of the plate-fin heat exchanger;
- c) dimensions and location of supports;
- d) overall plate-fin heat exchanger dimensions;
- e) type and details of fins used;
- f) presence and location of any inactive areas;
- g) mass of the plate-fin heat exchanger, both empty and full of liquid with a specific gravity of 1,0;
- h) centre of gravity of the plate-fin heat exchanger for empty and operating conditions;
- i) material specifications for all components;
- j) allowable forces and moments on connections;
- k) size, flange rating and facing, location, orientation, and flow identification of all connections;
- l) applicable design codes.

**5.1.2** If controlled torquing of flange bolting is required the vendor shall furnish torquing requirements.

**5.1.3** The vendor shall furnish detailed instructions on lifting and handling of the plate-fin exchanger.

**5.1.4** The review of general arrangement drawings by the purchaser shall not relieve the vendor of the responsibility of meeting the requirements of the purchase order.

**5.1.5** After receipt of the purchaser's general arrangement drawing review comments, the vendor shall furnish the certified general arrangement drawings and the detail drawings.

- **5.1.6** If specified by the purchaser, the vendor shall furnish copies of applicable welding procedure specifications and weld maps for review or record.
- **5.1.7** If specified by the purchaser, brazing procedures shall be made available for purchaser's review.
- **5.1.8** If specified by the purchaser, the vendor shall furnish copies of applicable calculations for review or record.
- **5.1.9** If specified by the purchaser, the vendor shall furnish stress analysis calculations in accordance with the methods prescribed by the applicable pressure design code for review or record.

**5.1.10** The vendor shall furnish procedures for pressure and leak testing, and drying for review.

## 5.2 Final records

5.2.1 The vendor shall furnish the purchaser with a user's manual which shall contain the following:

- a) technical description;
- b) operating instructions (including any start-up or shut-down constraints);
- c) installation and maintenance instructions (including lifting and handling);
- d) data sheets and drawings (as-built).

5.2.2 The vendor shall retain, for at least five years, records which confirm compliance of the material and fabrication with the requirements of this part of ISO 15547.

## 6 Design

### 6.1 General

If the design method is based on proof testing, the vendor shall provide the necessary details to the purchaser for verification of compliance with the pressure design code.

### 6.2 Design temperature

- The purchaser shall specify a maximum design temperature and a minimum design metal temperature.

### 6.3 Design pressure

The plate-fin heat exchanger design shall not be based on differential pressure.

### 6.4 Thermal stress

- 6.4.1 In addition to the design operating condition(s), the purchaser shall specify all operating conditions which could impose significant thermal stresses on the plate-fin heat exchanger. This shall consider any alternative operating cases, turn-down operation, upset-operation cases (with particular attention to cases where a stream's flowing condition might change or cease abruptly), and the process control philosophy being applied to the plate-fin heat exchanger. The purchaser shall specify which streams are subject to cyclic or frequently-repeated temperature fluctuations.

6.4.2 The vendor's design shall allow for thermally induced stresses, with the following assumptions:

- a) a local temperature difference of 50 K (90 °F) between any two adjacent streams;
- b) a local temperature difference of 30 K (54 °F) between any two adjacent streams in two-phase flow, or in transient or cyclic conditions.

### 6.5 Fouling resistance

A fouling resistance of zero shall be assumed unless otherwise specified by the purchaser.

NOTE Plate-fin heat exchangers are typically only suitable for clean services.

### 6.6 Corrosion allowance

The corrosion allowance shall be zero.

## 6.7 Components

6.7.1 The vendor shall provide details of the reaction at the support points.

- 6.7.2 If specified by the purchaser, the units shall have an earthing lug or boss.

## 6.8 Connections

- 6.8.1 If specified by the purchaser, the plate-fin heat exchanger, assemblies and manifolds shall be self-draining and self-venting through the connections for all pass arrangements.
- 6.8.2 The projection of flanged connections shall allow through-bolting to be removed from either side of the flange without removing the insulation. The insulation thickness shall be specified by the purchaser.
- 6.8.3 All bolt holes for flanged or studed connections shall straddle centrelines.
- 6.8.4 Connection sizes of DN 32 (NPS 1-1/4), DN 65 (NPS 2-1/2), DN 90 (NPS 3-1/2) or DN 125 (NPS 5) shall not be used.
- 6.8.5 The vendor shall prepare the ends of nozzles that are to be welded by others, unless otherwise approved by the purchaser.
- 6.8.6 The vendor shall perform calculations proving the adequacy of aluminium alloy pipe flanges, considering the mating flange, bolting and gasket materials as specified by the purchaser. The differential thermal expansion of bolting and flanges shall be considered.
- 6.8.7 Inactive areas in plate-fin heat exchangers, such as dummy layers, shall be ventable and drainable.
- 6.8.8 Unless otherwise specified by the purchaser, each nozzle shall be capable of withstanding the simultaneous applications of the resultant moments and forces defined in Figure 3 and Table 1.

These resultant forces,  $F_r$ , and moments,  $M_r$ , are as follows:

$$M_r = \sqrt{M_x^2 + M_y^2 + M_z^2}$$

$$F_r = \sqrt{F_x^2 + F_y^2 + F_z^2}$$

## 6.9 Metal temperature monitoring

Unless otherwise specified by the purchaser, the vendor shall provide suitable metal-temperature indicating devices at locations on the plate-fin heat exchanger to allow the operator to measure and monitor cool-down and warm-up rates.

## 6.10 Handling devices

The plate-fin heat exchanger shall be provided with suitable lifting lugs, holes or similar devices. The vendor's lifting design shall be based on twice the empty mass of the plate-fin heat exchanger.

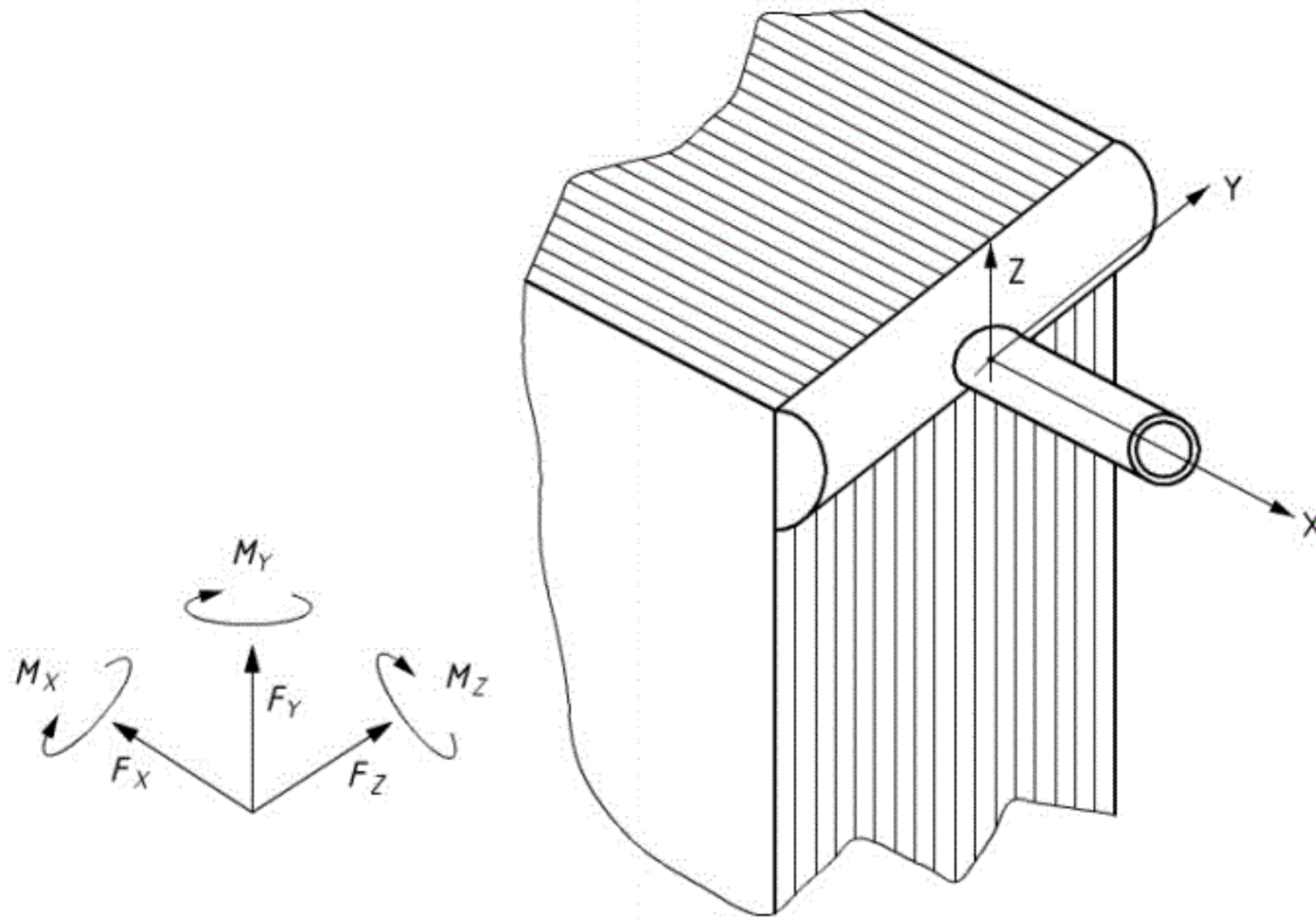

Figure 3 — Positions of the three reference axes

Table 1 — Resultant forces and moments allowable at nozzle-to-header intersection

Nominal diameter		Resultant moment		Resultant force	
		$M_r$		$F_r$	
DN	(NPS)	N·m	(lbf·ft)	N	(lbf)
50	(2)	60	(44)	405	(91)
80	(3)	165	(122)	750	(169)
100	(4)	330	(243)	1 330	(299)
150	(6)	765	(564)	1 800	(405)
200	(8)	1 080	(797)	2 770	(623)
250	(10)	1 350	(996)	3 370	(758)
300	(12)	1 650	(1 217)	4 500	(1 012)
350	(14)	1 950	(1 438)	5 400	(1 214)
400	(16)	2 320	(1 711)	6 450	(1 450)
450	(18)	2 700	(1 992)	7 500	(1 686)
500	(20)	3 000	(2 213)	8 250	(1 855)
600	(24)	3 600	(2 655)	10 300	(2 316)

## 7 Materials

7.1 The vendor shall select materials based upon their brazeability, weldability and suitability for the process service. For information, suitable materials are included in Annex A.

- **7.2** The purchaser shall specify the quantity of mercury, organo-mercuric compounds and heavy metals that will be present in the fluids in contact with the plate-fin heat exchanger. If water is present, the purchaser shall also specify the quantity of H<sub>2</sub>S, NH<sub>3</sub>, CO<sub>2</sub>, SO<sub>2</sub>, NOX, CO, Cl, the presence of halides and the pH value.

**7.3** The vendor shall ensure the selection of materials that shall not induce corrosion.

**7.4** Nozzles smaller than DN 300 (NPS 12) shall be manufactured from seamless pipe, unless otherwise approved by the purchaser.

**7.5** The nameplate shall be of corrosion-resistant material, such as an aluminium alloy or austenitic stainless steel.

## **8 Fabrication**

### **8.1 Welding and brazing**

**8.1.1** All pressure-containing welding and brazing shall be in accordance with the pressure design code. Structural welding shall be in accordance with the structural welding code, unless otherwise specified by the purchaser.

**8.1.2** All pressure-containing welds shall be full penetration.

**8.1.3** Buttwelded joints shall achieve complete penetration and full fusion and shall comply with the pressure design code.

**8.1.4** After arc, flame or similar non-mechanical cutting, all fused metal and metal whose mechanical or chemical properties have been altered by the cutting process shall be removed by mechanical means.

**8.1.5** The oxygen arc method shall not be used to cut aluminium materials.

**8.1.6** Backing rings may be used only if the back of the weld is inaccessible and if approved by the purchaser.

**8.1.7** The requirements for welding within this part of ISO 15547 shall apply to all welds on pressure parts, including permanent and temporary attachments.

**8.1.8** Temporary attachments or arc strikes on the pressure parts shall be avoided as far as practicable. If they occur, they shall be removed and the surface shall be properly conditioned to eliminate surface stress raisers. Such surfaces shall be examined by the liquid penetrant method.

**8.1.9** Welding of aluminium shall be performed using gas tungsten arc or gas metal arc welding, using inert gas shielding.

**8.1.10** The vendor shall demonstrate that any proprietary welded transition components between stainless steel and aluminium are equivalent to the pressure, bending and fatigue strength of the weaker of the materials to be joined.

### **8.2 Reinforcing pads and wear plates**

**8.2.1** All reinforcing pads shall be continuously welded and have one 6 mm (1/4 in) tapped hole in each segment for venting. Vent holes shall be plugged with a plastic plug or equivalent after testing.

**8.2.2** Each segment of each reinforcing pad and wear plate shall be tested with dry air or nitrogen, at a gauge pressure of 100 kPa (15 psi).

**8.2.3** If wear plates are continuously welded they shall have a vent hole.

### 8.3 Tolerances

Standard tolerances for the external dimensions of plate-fin heat exchangers are shown in Figures 4 and 5. The core centreline (Figure 4) and the base line of supports (Figure 5) are used as datum lines to illustrate these dimensions.

Figure 6 shows the tolerances for a manifolded assembly of two cores and also flange tolerances.

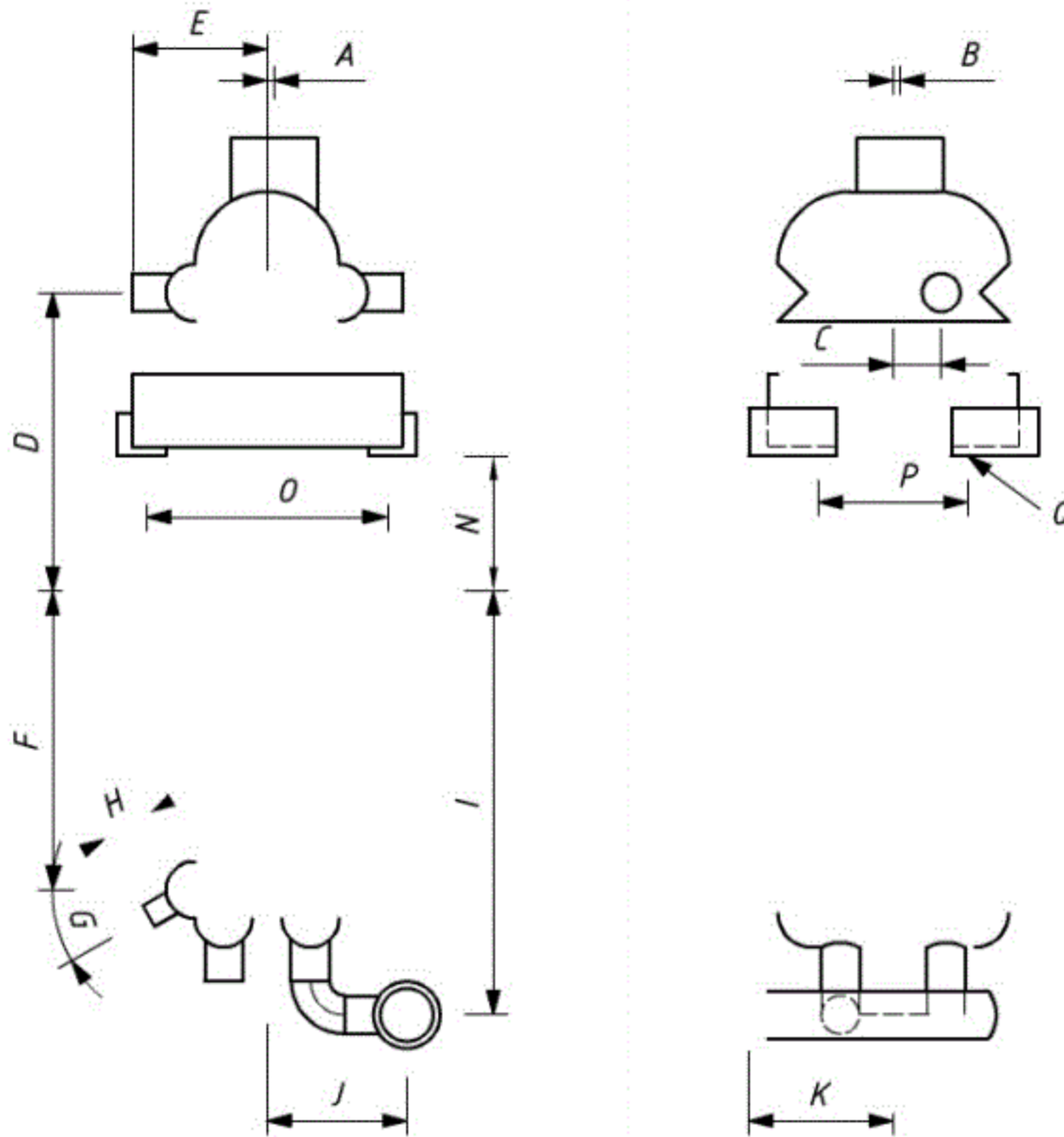

1

Dimension	Tolerance
<i>A, B, C, D, E, F, H, I, J, K</i>	$\pm 6 \text{ mm (1/4 in)}$ for dimensions $\leq 1\,000 \text{ mm (39 in)}$ $\pm 8 \text{ mm (5/16 in)}$ for dimensions $1\,000 \text{ mm (39 in)} \leq 2\,000 \text{ mm (78 in)}$ $\pm 10 \text{ mm (3/8 in)}$ for dimensions $> 2\,000 \text{ mm (78 in)}$
<i>G</i>	$\pm 3^\circ$
<i>N, O, P</i>	$\pm 3 \text{ mm (1/8 in)}$
<i>Q</i> (bolt-hole diameter)	$\pm 1 \text{ mm (1/16 in)}$

**Key**

1 core centreline

**Figure 4 — External dimensions of one core using the core centreline**

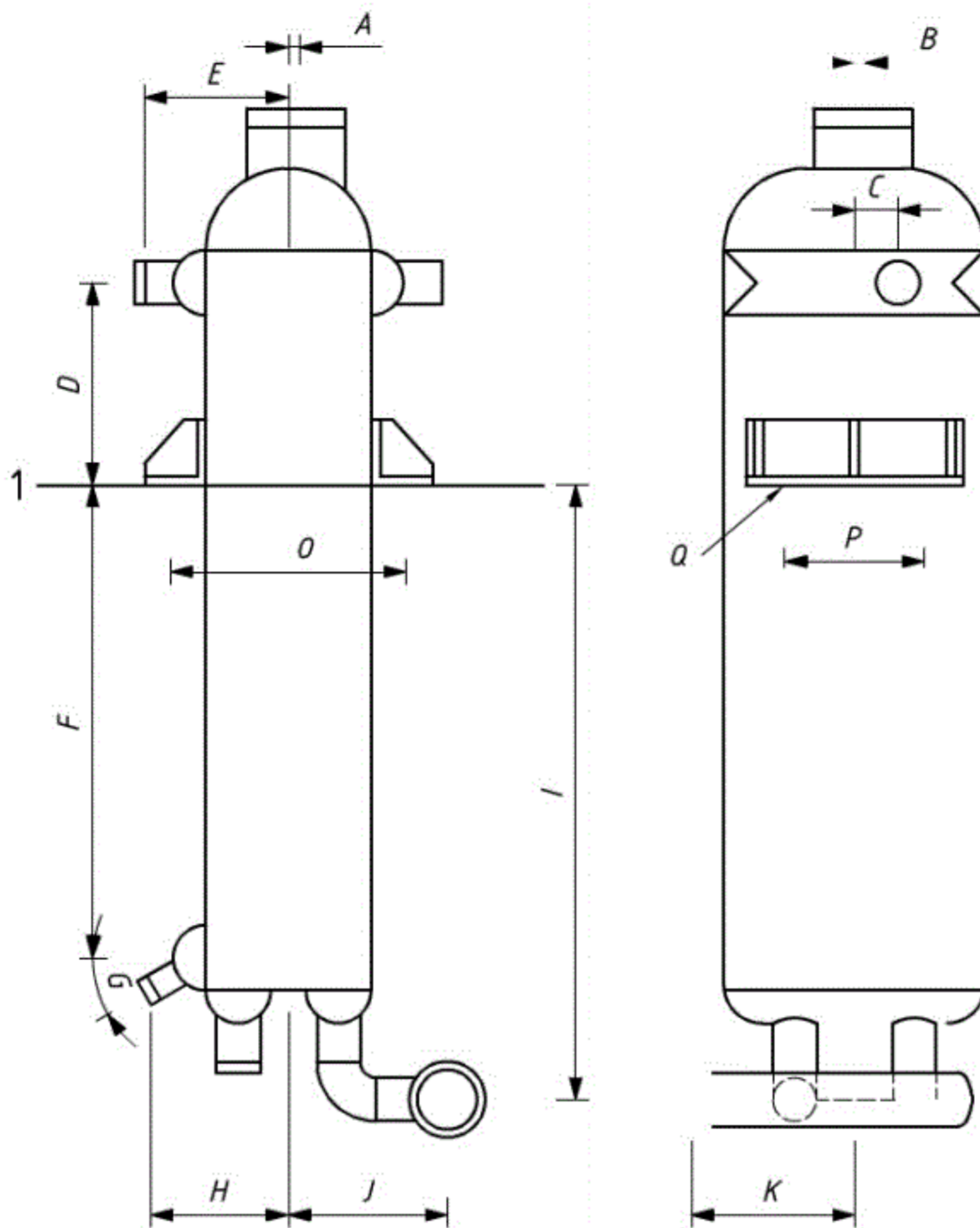

Dimension	Tolerance
<i>A, B, C, D, E, F, H, I, J, K</i>	$\pm 6 \text{ mm (1/4 in)}$ for dimensions $\leq 1\,000 \text{ mm (39 in)}$ $\pm 8 \text{ mm (5/16 in)}$ for dimensions $1\,000 \text{ mm (39 in)} \leq 2\,000 \text{ mm (78 in)}$ $\pm 10 \text{ mm (3/8 in)}$ for dimensions $> 2\,000 \text{ mm (78 in)}$
<i>G</i>	$\pm 3^\circ$
<i>O, P</i>	$\pm 3 \text{ mm (1/8 in)}$
<i>Q</i> (bolt-hole diameter)	$\pm 1 \text{ mm (1/16 in)}$

**Key**

1 support base line

**Figure 5 — External dimensions of one core using the support base line**



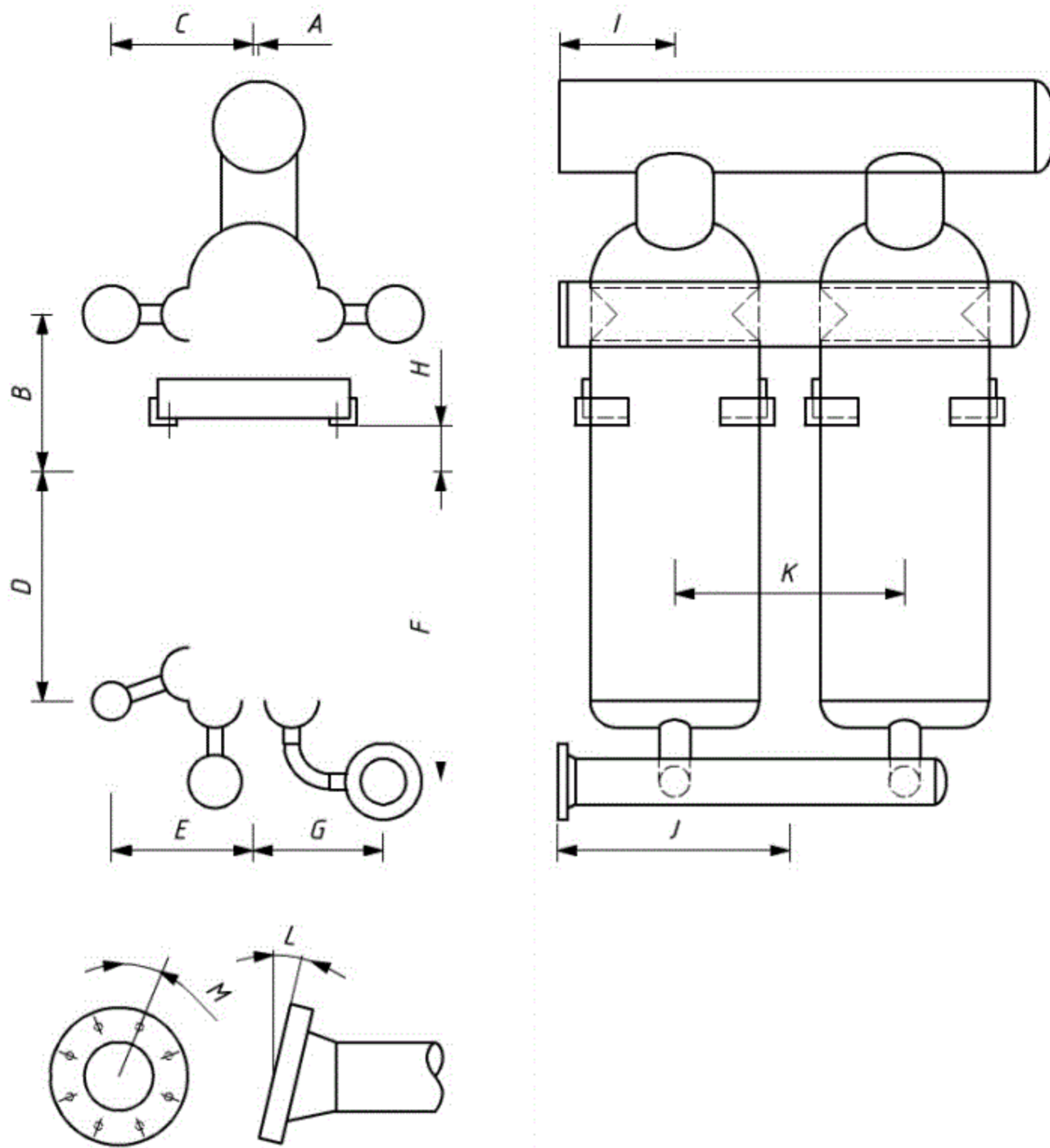

Dimension	Tolerance
<i>A, B, C, D, E, F, G, I, J, K</i>	$\pm 6 \text{ mm (1/4 in)}$ for dimensions $\leq 1\,000 \text{ mm (39 in)}$ $\pm 8 \text{ mm (5/16 in)}$ for dimensions $1\,000 \text{ mm (39 in)} \leq 2\,000 \text{ mm (78 in)}$ $\pm 10 \text{ mm (3/8 in)}$ for dimensions $> 2\,000 \text{ mm (78 in)}$
<i>H</i>	$\pm 3 \text{ mm (1/8 in)}$
<i>L</i>	$\pm 1^\circ$ and maximum $5 \text{ mm (3/16 in)}$ at flange periphery
<i>M</i>	$\pm 1^\circ$ and maximum $5 \text{ mm (3/16 in)}$ at bolt circle

Figure 6 — External dimensions of a manifolded assembly of two cores, and general flange details

## 9 Inspection and testing

### 9.1 Quality control

- **9.1.1** If specified by the purchaser, the vendor shall supply information about its quality control system and shall supply a quality control plan.

**9.1.2** Weld inspection requirements shall be as follows:

- a) All accessible butt welds shall be spot-radiographed as a minimum;
- b) 100 % radiographic examination shall be performed on any welded seam in a fabricated header that has been subjected to severe working (ratio of thickness to local radius greater than 5 %) after welding;
- c) On pressure parts, all attachment welds (fillet, structural attachment, lug, etc.) with a throat greater than 6 mm (1/4 in) shall be examined and evaluated by the liquid penetrant method in accordance with the pressure design code. Any surface irregularities which interfere with the examination shall be removed by grinding or machining. Indications from an adjacent brazed fusion line may be ignored.

**9.1.3** The design and fabrication of bimetal transition pieces, such as stainless steel to aluminium, shall be qualified by a prototype test prior to its first use, as follows.

- a) Prior to pressure testing the transition piece shall be thermally shocked in accordance with the following procedure:
  - 1) immerse in, and bring to the temperature of, boiling water;
  - 2) immerse in, and bring to the temperature of, liquid nitrogen;
  - 3) re-immerses in, and bring to the temperature of, boiling water.
- b) Hydrostatic or pneumatic test at 150 % of design pressure.
- c) If a helium test is specified for the completed unit, the transition piece shall be helium-tested prior to installation.

### 9.2 Pressure and leak testing

**9.2.1** Plate-fin heat exchangers shall be pressure tested in accordance with the pressure design code.

In low-temperature service [below 0 °C (32 °F)] the pressure test shall be pneumatic, except that it shall be hydrostatic if

- hydrostatic testing is required by the pressure design code, or
- pneumatic testing is prohibited by safety regulations or the manufacturer's safety requirements.

If a hydrostatic test is performed, the manufacturer shall assure that the plate-fin heat exchanger is thoroughly dried prior to shipment.

The selected pressure test method shall be subject to the agreement of the purchaser.

**9.2.2** Each chamber shall be individually tested without pressure in adjacent chambers.

**9.2.3** The test pressure for each test shall be held for a sufficient time to allow a thorough inspection and detection of small seepage leaks.

**9.2.4** For each pressure test, two indicating gauges (or one indicating gauge and one recording gauge) shall be attached to the plate-fin heat exchanger.

**9.2.5** The water used for hydrotesting shall be potable.

**9.2.6** The chloride content of the test water used for equipment with austenitic stainless steel components that would be exposed to the test fluid, shall not exceed 50 mg/kg (50 parts per million by mass). Upon completion of the hydrostatic test, the equipment shall be promptly drained and cleared of residual test fluid.

**9.2.7** Unless otherwise agreed between the purchaser and the vendor, helium leak tests shall be conducted in accordance with 9.2.8 and 9.2.9. Helium leak tests shall be performed after pressure testing. The plate-fin heat exchanger shall be thoroughly dried prior to helium leak testing.

**9.2.8** External helium leak test shall be performed as follows:

- a) All chambers of the plate-fin heat exchanger shall be evacuated and directly connected to the gas detector.
- b) The plate-fin heat exchanger shall be sealed within a non-metallic cover and the space between the cover and the plate-fin exchanger shall be filled with helium.
- c) Unless otherwise agreed between the purchaser and the vendor, the allowable leakage rate shall be  $10^{-4}$  kPa·m<sup>3</sup>/s [at a pressure difference of 100 kPa (15 psi)].

**9.2.9** Interstream helium leak test shall be performed as follows:

- a) The chamber that will contain the highest operating pressure shall be tested first for leaks into the other chambers, followed by the other chambers tested in order of reducing operating pressure.
- b) Helium shall be successively admitted into the test chamber.
- c) The other chambers shall be evacuated and connected to a gas detector.
- d) Unless otherwise agreed between the purchaser and vendor, the maximum allowable leakage rate shall be  $10^{-6}$  kPa m<sup>3</sup>/s (at a pressure difference equal to the design pressure) or  $10^{-7}$  kPa m<sup>3</sup>/s [at a pressure difference of 100 kPa (15 psi)].

### **9.3 Rectification**

**9.3.1** Defects resulting from fabricating operations shall be re-fabricated or repaired. Repairs require a written procedure with acceptance by the purchaser prior to the repair, including re-examination for defects and retesting for pressure and leaks in the original manner.

**9.3.2** If rectification requires blocking of a layer, the supplier shall use a proven procedure developed for this purpose. Any blocking of an active layer shall be notified to the purchaser.

**9.3.3** If the plate-fin heat exchanger is supplied with blocked layer(s), the vendor shall supply calculations that confirm the adequacy of the unit for the originally specified requirements.

## 9.4 Nameplate

**9.4.1** A nameplate shall be permanently attached to each individual plate-fin heat exchanger.

**9.4.2** The nameplate shall be attached either to a bracket welded to the plate-fin heat exchanger or to the plate-fin heat exchanger surface. If the plate-fin heat exchanger is to be installed in a permanent enclosure, (e.g. a coldbox or vessel), a second identical (duplicate) nameplate shall be supplied loose by the vendor, for attachment onto the enclosure by others.

**9.4.3** Because plate-fin heat exchangers are capable of accommodating more than two streams, i.e. contain more than two independent pressure chambers, it is common practice that nameplates used by vendors are able to specify data for several streams. Alternatively, several nameplates can be used.

**9.4.4** Standard nameplate data shall include

- a) vendor's name and plate-fin heat exchanger serial number,
- b) purchaser's item number,
- c) year built,
- d) pressure design code and if required, code stamping,
- e) maximum design temperature and minimum design metal temperature,
- f) design/maximum allowable working pressure, and vacuum if applicable,
- g) test pressure and method, and
- h) mass (empty).

## 10 Preparation for shipment

**10.1** The internal and external surfaces of the plate-fin heat exchanger shall be free from oil and grease and from any loose scale or other foreign material.

**10.2** Openings in dummy passages or inactive plate-fin heat exchanger areas shall be suitably protected to avoid ingress of water and dust.

**10.3** Each stream of the plate-fin heat exchanger shall be dried to a dew point less than  $-30\text{ }^{\circ}\text{C}$  ( $-22\text{ }^{\circ}\text{F}$ ).

**10.4** To avoid ingress of any moisture or dust during transport, plate-fin heat exchangers shall be shipped with nozzles hermetically sealed and all pressure chambers pressurized with dry, oil-free nitrogen gas or air at a gauge pressure of at least 20 kPa (3 psi). Each stream shall be provided with a pressure gauge and valve.

**10.5** All connections shall carry warning labels stating that the plate-fin heat exchanger is under pressure.

## **Annex A** **(informative)**

### **Recommended practice**

#### **A.1 General**

This annex has been prepared to give advice to the designer. The advice is not mandatory and is offered for guidance only.

In this annex, the numbers in parentheses after the clause headings correspond to those in the main body for that subject, but are prefixed by the letters "RP".

#### **A.2 Strainers (RP 4.5)**

The purchaser should install a strainer upstream of the plate-fin heat exchanger to remove particles which exceed 30 % of the nominal plate/fin gap.

#### **A.3 Drawings and other data requirements (RP 5)**

In some cases it might be necessary to ask the vendor to provide and/or maintain a detailed manufacturing record book (MRB). A suggested contents list for the MRB is given:

- a) certificate of conformance;
- b) non-conformance report;
- c) vendor's data report, as specified by the design code;
- d) code calculations;
- e) material traceability, certified mill test reports for all pressure parts including plates;
- f) weld and non-destructive examination (NDE) documentation;
- g) hydrostatic test or helium test report/certificate or chart;
- h) nameplate rubbings or photocopy;
- i) third-party verification and certification.

## A.4 Design — Thermal stress (RP 6.4)

**A.4.1** Brazed aluminium plate-fin heat exchangers are relatively compact, rigid structures and are susceptible to damage if subjected to operating conditions which produce excessive thermal stresses. Thermal stress can result from the normal presence of streams at different temperatures, as well as stresses which develop due to transient and/or cyclic operating conditions.

**A.4.2** Brazed aluminium plate-fin heat exchangers are susceptible to thermal stresses during start-up and shut-down operation, and should be brought to and from operating temperatures gradually in accordance with the following:

- a) unless other limitations apply, cool-down and warm-up of the plate-fin heat exchanger should be controlled to a rate of no more than 2 °C/min (4 °F/min), measured at a suitable location(s) on the plate-fin heat exchanger;
- b) liquid or two-phase streams should not be introduced into the plate-fin heat exchanger if the difference between the fluid's inlet temperature and the plate-fin heat exchanger's local metal temperature exceeds 30 °C (54 °F);
- c) vapour streams should not be introduced if the temperature difference between the fluid's inlet temperature and the plate-fin heat exchanger's local metal temperature exceeds 50 °C (90 °F);
- d) if specified by the purchaser, the vendor shall review the purchaser's start-up and shut-down operating procedures prior to the initial commissioning of the plate-fin heat exchanger.

## A.5 Design — Corrosion (RP 6.6)

**A.5.1** In water service the pH value should remain between 4,5 and 8,5.

**A.5.2** In all cases the presence of halides and heavy metal ions should be avoided because elemental mercury is a trace contaminant in some natural gas feedstocks and may deposit over time as a solid foulant in cold service plate-fin heat exchangers. When equipment temperatures are raised above the melting point of mercury (e.g. during operational excursions or shutdowns) these deposits can liquefy, accumulate and result in degradation of aluminium through several mechanisms. For such cases a mercury removal system should be considered,

## A.6 Design — Connections (RP 6.8.8)

The nozzle loads from attached piping are seldom defined at the time of order placement for a plate-fin heat exchanger. In addition, the allowable nozzle loads for plate-fin heat exchangers are generally lower than the calculated loads for pipe or piping flanges. It is desirable in the design stage that the plate-fin heat exchanger vendor and piping designers work on agreed levels of nozzle loadings that can be taken by the plate-fin heat exchanger. When actual piping nozzle loads become available, these should be submitted to the vendor to confirm their acceptability.

## A.7 Materials (RP 7)

Materials for aluminium plate-fin heat exchangers are selected for their brazeability, weldability and other characteristics. Typical materials used in construction, and their maximum applicable design temperatures, are shown in Table A.1.

**Table A.1 — Typical materials used in the construction of brazed aluminium plate-fin heat exchangers and their maximum applicable design temperature.**

Component	Material					
	American (ASME)		European (EN)		Japanese (JIS)	
	Alloy No.	Max. applicable design temperature <sup>a</sup>	Alloy no.	Max. applicable design temperature <sup>b</sup>	Alloy No.	Max. applicable design temperature <sup>c</sup>
Heat transfer fin/ Distributor fin	SB-209				H4000	
	Grade 3003	204 °C (400 °F)	AW-3003	250 °C (482 °F)	Grade A3003P	200 °C (392 °F)
	Grade 3004	204 °C (400 °F)			Grade A3004P	200 °C (392 °F)
Side bar/ Centre bar	SB-221				H4100	
	Grade 3003	204 °C (400 °F)	AW-3003	250 °C (482 °F)	Grade A3003S	200 °C (392 °F)
Parting sheet <sup>d</sup> / Cap sheet <sup>d</sup>	SB-209		AW-3003	250 °C (482 °F)	H4000	
	Grade 3003	204 °C (400 °F)			Grade A3003P	200 °C (392 °F)
Header	SB-209, 221 and 241				H4000	
	Grade 3003	204 °C (400 °F)			Grade A3003P	200 °C (392 °F)
	Grade 5052	204 °C (400 °F)	AW-5754	100 °C (212 °F)	Grade A5052P	200 °C (392 °F)
	Grade 5083	65 °C (150 °F)	AW-5083	65 °C (150 °F) <sup>e</sup>	Grade A5083P	65 °C (150 °F)
	Grade 5454	204 °C (400 °F)			Grade A5454P	200 °C (392 °F)
	Grade 6061	204 °C (400 °F)			Grade A6061P	200 °C (392 °F)
Nozzle	SB-209, 221 and 241				H4080 and H4000	
	Grade 3003	204 °C (400 °F)			A3003TID and TE	200 °C (392 °F)
	Grade 5052	204 °C (400 °F)	AW-5754	100 °C (212 °F)	A3003P	200 °C (392 °F)
	Grade 5083	65 °C (150 °F)	AW-5083	65 °C (150 °F) <sup>e</sup>	A5052TID and TE	200 °C (392 °F)
	Grade 5086	65 °C (150 °F)			A5052P	200 °C (392 °F)
	Grade 5454	204 °C (400 °F)			A5083TID and TE	65 °C (150 °F)
	Grade 6061	204 °C (400 °F)			A5083P	65 °C (150 °F)
					A5086P	65 °C (150 °F)
	SB-221 and SB-241				A5454TE	200 °C (392 °F)
	Grade 6063	204 °C (400 °F)			A5454P	200 °C (392 °F)
				A6061 TD and TE	200 °C (392 °F)	
				A6061P	200 °C (392 °F)	
				A6063TID and TE	200 °C (392 °F)	
Flange	SB-247				H4140	
	Grade 5083	65 °C (150 °F)	AW-5083	65 °C (150 °F) <sup>e</sup>	Grade A5083FD	65 °C (150 °F)
	Grade 6061	204 °C (400 °F)	AW-5754	100 °C (212 °F)	Grade A6061FD	200 °C (392 °F)
Support	SB-209 and 221				H4000	
	Grade 5052	204 °C (400 °F)	AW-5754	100 °C (212 °F)	Grade A5052P	200 °C (392 °F)
	Grade 5083	65 °C (150 °F)	AW-5083	65 °C (150 °F) <sup>e</sup>	Grade A5083P	65 °C (150 °F)
	Grade 6061	204 °C (400 °F)			Grade A6061P	200 °C (392 °F)
	Grade 6063	204 °C (400 °F)	AC- Al Si 7 Mg	130 °C (266 °F)		

<sup>a</sup> Maximum applicable temperature in accordance with ASME Section VIII Division 1, where the designated units are in degrees Fahrenheit.

<sup>b</sup> Maximum applicable temperature in accordance with EN 12392, where the designated units are in degrees Celsius. These temperature limits were established for pressure-containing parts; for other parts, higher values may be used if test or service experience have demonstrated that these alloys are suitable at such temperatures.

<sup>c</sup> Maximum applicable temperature per Japanese high pressure gas safety law, where the designated units are in degrees Celsius.

<sup>d</sup> May be clad.

<sup>e</sup> Higher temperatures may also be used if test or service experience have demonstrated that these alloys are suitable at such temperatures for specific duty.

## Annex B (informative)

### Plate-fin heat exchanger checklist

Completion of the checklist is the responsibility of the purchaser.

This checklist is used for listing the purchaser's specific requirements for which the clauses or subclauses within this part of ISO 15547 include a choice or which designate, by use of a bullet (●) in the margin, that a decision is required.

Subclause	Requirement	Item	
3.1	Specify (or agree) pressure design code	Complete on data sheet	
3.1	Specify (or agree) structural welding code	Complete on data sheet	
3.3	Compliance with applicable local regulations	Complete on data sheet	
3.4	Specify if national, state or local codes require that the vendor register each plate-fin heat exchanger	Yes (clarify requirements)	No
4.6	Specify if mercury-tolerant design is required	Complete on data sheet	
5.1.6	Welding procedure specification and weld map to be furnished by vendor for review or record	Yes (clarify requirements)	No
5.1.7	Brazing procedures shall be made available for purchaser's review	Yes	No
5.1.8	Calculations to be furnished by vendor for review or record	Yes (clarify requirements)	No
5.1.9	Stress analysis calculations to be furnished for review or record	Yes (clarify requirements)	No
6.2	Specify a maximum design temperature and a minimum design metal temperature	Complete on data sheet	
6.4.1	Specify all operating conditions which might impose significant thermal stresses on the plate-fin heat exchanger streams, or which are subject to cyclic or frequently repeated temperature fluctuations	Complete on data sheet	
6.7.2	Specify requirement for and type of earthing e.g. Lug or Boss	Complete on data sheet	
6.8.1	Specify requirement for self-draining and self-venting	Complete on data sheet	
6.8.2	Is insulation required? If, yes, specify insulation thickness	Yes	No
7.2	Specify the quantity of Hg; organo-mercuric compounds and heavy metals that will be present in the fluids in contact with the plate-fin heat exchanger. If water is present, the purchaser shall also specify the quantity of H <sub>2</sub> S, NH <sub>3</sub> , CO <sub>2</sub> , SO <sub>2</sub> , NOX, CO, Cl, the presence of halides and the pH value.	Complete on data sheet	
9.1.1	Specify if information required on quality control system and if quality control plan required	Yes (clarify requirements)	No



## **Annex C** (informative)

### **Plate-fin heat exchanger data sheets**

The following data sheets are provided to assist the designer, vendor and user to specify the data necessary for the design of a plate-fin heat exchanger for petroleum and natural gas services. If a unit contains more than three streams (fluids), additional process data sheets should be used.

Completion of the data sheets is a joint responsibility of the purchaser and the vendor. The purchaser (owner or contractor) is responsible for the process data, which define the purchaser's explicit requirements.

After the plate-fin heat exchanger has been fabricated, the vendor should complete the data sheets to make a permanent record that accurately describes the equipment "as-built".

<b>Company</b>	<b>BRAZED ALUMINIUM PLATE-FIN HEAT EXCHANGER DATA SHEET (SI UNITS) PROCESS</b>	<b>Engineering contractor</b>
<b>PO No.:</b>	<b>Doc. No.:</b>	<b>Page 1 of</b>

Customer:	Item No.:
Project:	Manufacturer:
Location:	Order/enq. No.:

01 Service:	Total heat transfer area: (m <sup>2</sup> )	
02 Number of cores:	Cores connected in parallel:	Cores connected in series:
03 No. cores per assembly:	No. of assemblies:	Thermal transmittance (Overall heat transfer coefficient): (W/m <sup>2</sup> ·K)
04 Total number of layers (including dummy layers):	Flow pattern: counter, cross-counter, cross, parallel	
05	Core size: width (mm), height (mm), length (mm)	

06 Fluid	A/	B/	C/
07 Total flow (kg/s)			
08 Design temperature (maximum) (°C)			
09 Minimum design metal temperature (°C)			
10 Design pressure [kPa (ga)]			
11 Pressure drop allow./calc. (kPa)	/	/	/
12 Hydrostatic test pressure [kPa (ga)]			
13 Pneumatic test pressure [kPa (ga)]			
14 MAWP [kPa (ga)]			

**15 OPERATING DATA**

16 Liquid flow (In/Out) (kg/s)	/	/	/
17 Vapour flow (In/Out) (kg/s)	/	/	/
18 Noncondensables flow (kg/s)			
19 Operating pressure [kPa (ga)]			
20 Operating temperature (In/Out) (°C)	/	/	/
21 Vacuum @ temperature [kPa (abs) @ °C]	@	@	@

**22 LIQUID PROPERTIES**

	INLET	OUTLET	INLET	OUTLET	INLET	OUTLET
23 Density (kg/ m <sup>3</sup> )						
24 Specific heat capacity (kJ/kg·K)						
25 Viscosity (mPa·s)						
26 Thermal conductivity (W/m·K)						
27 Surface tension (N/m)						

**28 VAPOUR PROPERTIES**

29 Density (kg/ m <sup>3</sup> )				
30 Specific heat capacity (kJ/kg·K)				
31 Viscosity (mPa·s)				
32 Thermal conductivity (W/m·K)				
33 Relative molecular mass (kg/kmol)				
34 Relative molecular mass, non-cond. (kg/kmol)				
35 Dew point/bubble point (°C)				
36 Latent heat (kJ/kg)				
37 Critical pressure [kPa (abs)]				
38 Critical temperature (°C)				
39 Heat exchanged (kW)				
40 Heat transfer area per core (m <sup>2</sup> )				
41 MTD (corrected) (°C)				
42 Fouling resistance (m <sup>2</sup> ·KW)				
43 Stream heat transfer coefficient (W/ m <sup>2</sup> ·K)				

Rev. No.	Revision	Date	Prepared by	Reviewed by
----------	----------	------	-------------	-------------

<b>Company</b>	<b>BRAZED ALUMINIUM PLATE-FIN HEAT EXCHANGER DATA SHEET (SI UNITS) MECHANICAL</b>	<b>Engineering contractor</b>
<b>PO No.:</b>	<b>Doc. No.:</b>	<b>Page 2 of</b>

<b>01 CORE CONSTRUCTION DETAIL</b>			
02	Number of layers per core		
03	Effective layer width (mm)		
04	Effective layer thermal length (mm)		
05	Heat transfer fin type		
06	Fin height x thickness (mm)	X	X
07	Fin number per metre		
08	Distributor type		
09	Distributor fin type		
10	Fin height x thickness (mm)	X	X
11	Fin number per metre		
<b>12 CONNECTIONS</b>			
13	Nozzle size (inlet/outlet) (DN)	/	/
14	Nozzle type/rating	/	/
15	Nozzle loads/moments (N)/(N.m)	/	/
16	Inlet manifold size (mm)		
17	Inlet manifold nozzle size (inlet/outlet) (DN)	/	/
18	Inlet manifold nozzle type/rating	/	/
19	Outlet manifold size (mm)		
20	Outlet manifold nozzle size (inlet/outlet) (DN)	/	/
21	Outlet manifold nozzle type/rating	/	/
22	Header size (inlet/outlet) (mm)	/	/
<b>23 COMPONENT</b>			
24	Parting sheet thickness: (mm)	Parting sheet material:	
25	Cap sheet thickness: (mm)	Cap sheet material:	
26	Side bar width: (mm)	Side bar material:	
27	Heat transfer fin material:		
28	Distributor fin material:		
29	Nozzle material:		
30	Manifold material:		
31	Header material:		
32	Nozzle pipes/flanges:		
33	Stud bolts/nuts:		
34	Support material:		
35			
36	Pressure vessel code		
37	Material certificate type		
38	Applicable specifications		
39	Local rules and regulations		
40	Local registration of plate-fin heat exchanger		
41	Code stamp	yes/no	
42	Stacking arrangement		
43			
44	Mass: Core (empty/operating)	(kg)	Assembly: (empty/operating) (kg)
45	<b>NOTES:</b>		
46			
47			
48			

Company	<b>BRAZED ALUMINIUM PLATE-FIN HEAT EXCHANGER DATA SHEET (SI UNITS) PHYSICAL PROPERTIES</b>	Engineering contractor
PO No.:	Doc. No.:	Page 3 of

01 Stream Designation:	Fluid Name:												
02 Composition	Component												
	Mole %												

03 04	Pressure [kPa (ga)]	Temperature (°C)	Heat released (KW)	Mass fraction vapour	Liquid phase					Vapour phase							
					Density (kg/m <sup>3</sup> )	Specific heat capacity (kJ/kg·K)	Viscosity (mPa·s)	Thermal conductivity (W/m·K)	Surface tension (N/m)	Density (kg/m <sup>3</sup> )	Specific heat capacity (kJ/kg·K)	Viscosity (mPa·s)	Thermal conductivity (W/m·K)	Relative molecular mass (kg/kmol)	Latent heat (kJ/kg)	Critical pressure [kPa (abs)]	Critical temperature (°C)
05																	
06																	
07																	
08																	
09																	
10																	
11																	
12																	
13																	
14																	
15																	
16																	
17																	
18																	
19																	
20																	
21																	
22																	
23																	
24																	
25																	
26																	
27																	
28																	
29																	
30																	
31																	
32																	

<b>Company</b>	<b>BRAZED ALUMINIUM PLATE-FIN HEAT EXCHANGER DATA SHEET (US CUSTOMARY UNITS) PROCESS</b>	<b>Engineering contractor</b>
<b>PO No.:</b>	<b>Doc. No.:</b>	<b>Page 1 of</b>

Customer:	Item No.:
Project:	Manufacturer:
Location:	Order/enq. No.:

01 Service:	Total heat transfer area: (ft <sup>2</sup> )	
02 Number of cores:	Cores connected in parallel:	Cores connected in series:
03 No. cores per assembly:	No. of assemblies:	Thermal transmittance (Overall heat transfer coefficient): (BTU/h·ft <sup>2</sup> ·°F)
04 Total number of layers (including dummy layers):	Flow pattern: counter, cross-counter, cross, parallel	
05	Core size: width (in) height (in), length (in)	

06 Fluid	A/	B/	C/
07 Total flow (lb/h)			
08 Design temperature (maximum) (°F)			
09 Minimum design metal temperature (°F)			
10 Design pressure (psig)			
11 Pressure drop allow./calc. (psi)	/	/	/
12 Hydrostatic test pressure (psig)			
13 Pneumatic test pressure (psig)			
14 MAWP (psig)			

**15 OPERATING DATA**

16 Liquid flow (In/Out) (lb/h)	/	/	/
17 Vapour flow (In/Out) (lb/h)	/	/	/
18 Noncondensables flow (lb/h)			
19 Operating pressure (psig)			
20 Operating temperature (In/Out) (°F)	/	/	/
21 Vacuum @ temperature [(psia)@ °F]	@	@	@

**22 LIQUID PROPERTIES**

	INLET	OUTLET	INLET	OUTLET	INLET	OUTLET
23 Density (lb/ft <sup>3</sup> )						
24 Specific heat capacity (BTU/lb·°F)						
25 Viscosity (cP)						
26 Thermal conductivity (BTU/ft·h·°F)						
27 Surface tension (dyne/cm)						

**28 VAPOUR PROPERTIES**

29 Density (lb/ft <sup>3</sup> )				
30 Specific heat capacity (BTU/lb·°F)				
31 Viscosity (cP)				
32 Thermal conductivity (BTU/ft·h·°F)				
33 Relative molecular mass (lb/lb-mol)				
34 Relative molecular mass, noncond. (lb/lb-mol)				
35 Dew point/bubble point (°F)				
36 Latent heat (BTU/lb)				
37 Critical pressure (psia)				
38 Critical temperature (°F)				
39 Heat exchanged (BTU/h)				
40 Heat transfer area per core (ft <sup>2</sup> )				
41 MTD (corrected) (°F)				
42 Fouling resistance (ft·h·°F/BTU)				
43 Stream heat transfer coefficient (BTU/ft·h·°F)				

Rev. No.	Revision	Date	Prepared by	Reviewed by
----------	----------	------	-------------	-------------

<b>Company</b>	<b>BRAZED ALUMINIUM PLATE-FIN HEAT EXCHANGER DATA SHEET (US CUSTOMARY UNITS) MECHANICAL</b>	<b>Engineering contractor</b>
<b>PO No.:</b>	<b>Doc. No.:</b>	<b>Page 2 of</b>

<b>01 CORE CONSTRUCTION DETAIL</b>			
02	Number of layers per core		
03	Effective layer width (in)		
04	Effective layer thermal length (in)		
05	Heat transfer fin type		
06	Fin height x thickness (in)	X	X
07	Fin number per inch		
08	Distributor type		
09	Distributor fin type		
10	Fin height x thickness (in)	X	X
11	Fin number per inch		
<b>12 CONNECTIONS</b>			
13	Nozzle size (inlet/outlet) (NPS)	/	/
14	Nozzle type/rating	/	/
15	Nozzle loads/moments (lbf) / (lbf.ft)	/	/
16	Inlet manifold size (in)		
17	Inlet manifold nozzle size (inlet/outlet) Nominal	/	/
18	Inlet manifold nozzle type/rating	/	/
19	Outlet manifold size (in)		
20	Outlet manifold nozzle size (inlet/outlet) (NPS)	/	/
21	Outlet manifold nozzle type/rating	/	/
22	Header size (inlet/outlet) (in)	/	/

<b>23 COMPONENT</b>	
24 Parting sheet thickness: (in)	Parting sheet material:
25 Cap sheet thickness: (in)	Cap sheet material:
26 Side bar width: (in)	Side bar material:
27 Heat transfer fin material:	
28 Distributor fin material:	
29 Nozzle material:	
30 Manifold material:	
31 Header material:	
32 Nozzle pipes/flanges:	
33 Stud bolts/nuts:	
34 Support material:	
35	
36 Pressure vessel code	
37 Material certificate type	
38 Applicable specifications	
39 Local rules and regulations	
40 Local registration of plate-fin heat exchanger	
41 Code stamp	Yes/no
42 Stacking arrangement	
43	
44 Mass: Core (empty/operating) (lb)	Assembly: (empty/operating) (lb)
<b>45 NOTES:</b>	
46	
47	
48	

<b>Company</b>	<b>BRAZED ALUMINIUM PLATE-FIN HEAT EXCHANGER DATA SHEET (US CUSTOMARY UNITS) PHYSICAL PROPERTIES</b>	<b>Engineering contractor</b>
<b>PO No.:</b>	<b>Doc. No.:</b>	<b>Page 3 of</b>

01 Stream Designation:	Fluid Name:												
02 Composition:	Component												
	Mole %												

03 04	Liquid phase									Vapour phase								
	Pressure (psig)	Temperature (°F)	Heat released (BTU/h)	Mass fraction vapour	Density (lb/ft <sup>3</sup> )	Specific heat capacity (BTU/lb·°F)	Viscosity (cP)	Thermal conductivity (BTU/ft h °F)	Surface tension (dyne/cm)	Density (lb/ft <sup>3</sup> )	Specific heat capacity (BTU/lb·°F)	Viscosity (cP)	Thermal conductivity (BTU/ft h °F)	Relative molecular mass (lb/lb mol)	Latent heat (BTU/lb)	Critical pressure (psig)	Critical temperature (°F)	
05																		
06																		
07																		
08																		
09																		
10																		
11																		
12																		
13																		
14																		
15																		
16																		
17																		
18																		
19																		
20																		
21																		
22																		
23																		
24																		
25																		
26																		
27																		
28																		
29																		
30																		
31																		
32																		

## Bibliography

- [1] EN 12392<sup>2)</sup>, *Aluminium and aluminium alloys — Wrought products — Special requirements for products intended for the production of pressure equipment*
- [2] EN 13445 (all parts), *Unfired pressure vessels*
- [3] ASME VIII Div. 1<sup>3)</sup>, *ASME Boiler and Pressure Vessel Code, Section VIII, Rules for construction of pressure vessels*

---

2) Comité Européen de Normalisation, 36, rue de Stassart, B-1050 Brussels, Belgium.

3) American Society of Mechanical Engineers, Three Park Avenue, New York, NY 10016-5990, USA.



Additional copies are available through Global Engineering Documents at (800) 854-7179 or (303) 397-7956

Information about API Publications, Programs and Services is available on the World Wide Web at <http://www.api.org>



1220 L Street, Northwest  
Washington, D.C. 20005-4070  
202-682-8000

Product No: CX662201